

XL Cleaner Sink Installation Instructions

Fixing screws not provided. The appropriate screw type should be selected for either a solid wall or timber stud wall application. If fixing to timber framed walls or partitioning the wall should be reinforced with a noggin in the appropriate location to receive fixing screws.

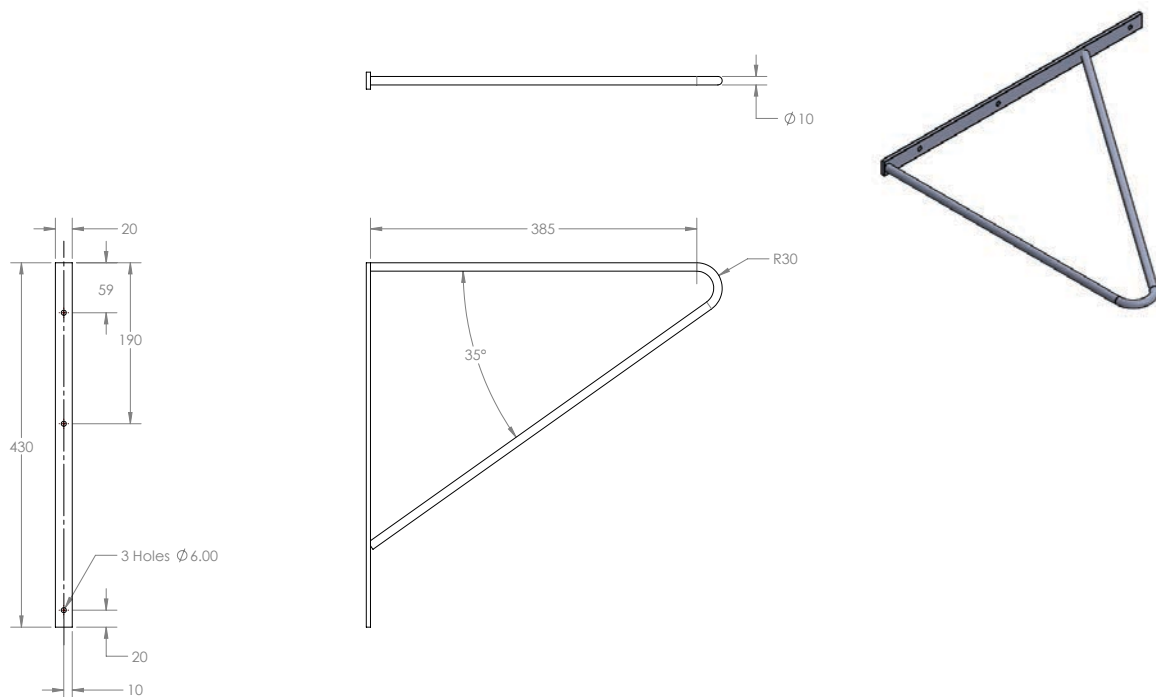

1. Mark bracket fixing points to achieve desired height

Note: Recommended overall height is 500-700mm from top of sink to finished floor (see diagram above for fixing points)

2. Drill holes as marked and install first wall bracket with appropriate fixing screws
3. Ensure that brackets have been installed parallel to each other and are level horizontally
4. Place XL Cleaner Sink onto brackets
5. Install 90mm waste
6. Connect waste trap